

FEDERAL SUPPLY CLASS
4730

REV.
C

RATIONALE

CLARIFIED NOTICE, ADDED "D" DIMENSION FOR SIZE -12, UPDATED NOTES, MATERIALS, PART NUMBERS, AND TABLE 2, AND CLARIFIED EXPLANATORY NOTES.

AS21923™

NOTICE

THE INITIAL PUBLICATION OF THIS DOCUMENT WAS TAKEN DIRECTLY FROM U.S. MILITARY STANDARD MS21923 AND RETAINS THE SAME PART NUMBERS ESTABLISHED BY THE ORIGINAL MILITARY DOCUMENT. PROCUREMENT OF MS21923 PART NUMBERS TO THIS "AS" STANDARD MAY RESULT IN LOSS OF CONFIGURATION CONTROL WHERE DIFFERENCES IN THE CANCELLED MIL-F-18280 AND THE SUPERSEDING AS18280 PROCUREMENT SPECIFICATIONS EXIST. AS5239 IS A RECOMMENDED REPLACEMENT STANDARD THAT ELIMINATES THIS PROBLEM.

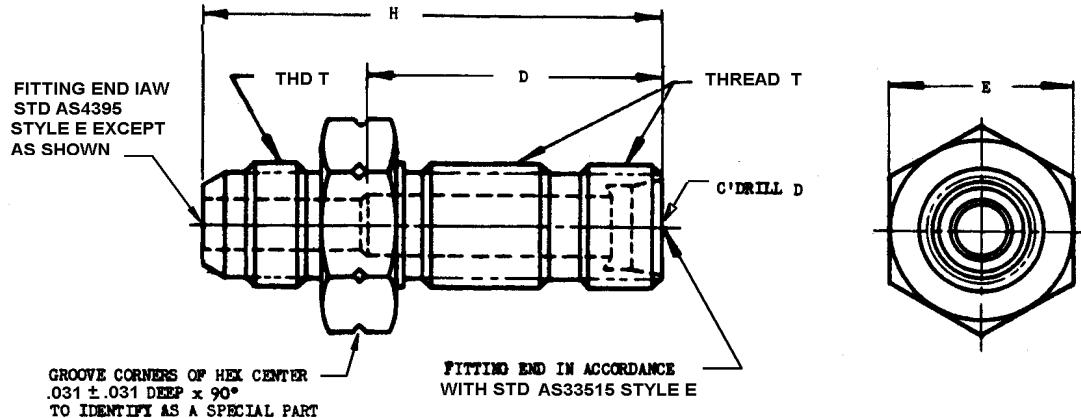

FIGURE 1 - ADAPTER, FLARELESS TUBE, BULKHEAD AND UNIVERSAL TO FLARED TUBE

TABLE 1 - DIMENSIONS

DASH NO. /5/	NOMINAL TUBE SIZE (REF)	T THREAD AS8879	H	E MIN - MAX	D +.031	WEIGHT, LB/EA, MAX		
						STEEL	AL ALLOY	TI ALLOY
-2	.125	.3125-24 UNJF-3A	1.531	.553- .566	.938	.032	.012	.018
-3	.188	.3750-24 UNJF-3A	1.625	.615- .628	THRU	.047	.017	.027
-4	.250	.4375-20 UNJF-3A	1.750	.678- .691	1.094	.062	.023	.035
-5	.313	.5000-20 UNJF-3A	1.781	.740- .753	THRU	.082	.031	.047
-6	.375	.5625-18 UNJF-3A	1.891	.803- .816	THRU	.094	.036	.054
-8	.500	.7500-16 UNJF-3A	2.125	.990-1.003	1.344	.172	.063	.099
-10	.625	.8750-14 UNJF-3A	2.375	1.113-1.128	1.469	.244	.089	.140
-12	.750	1.0625-12 UNJ-3A	2.656	1.363-1.380	1.594	.391	.143	.225
-16	1.000	1.3125-12 UNJ-3A	2.688	1.613-1.630	1.594	.533	.195	.307
-20	1.250	1.6250-12 UNJ-3A	2.734	1.863-1.880	1.594	.784	.288	.452
-24	1.500	1.8750-12 UNJ-3A	2.875	2.109-2.135	1.594	.972	.356	.560
-32	2.000	2.5000-12 UNJ-3A	3.563	2.734-2.760	2.000	TBD	TBD	TBD

SAE Technical Standards Board Rules provide that: "This report is published by SAE to advance the state of technical and engineering sciences. The use of this report is entirely voluntary, and its applicability and suitability for any particular use, including any patent infringement arising therefrom, is the sole responsibility of the user." SAE reviews each technical report at least every five years at which time it may be revised, reaffirmed, stabilized, or cancelled. SAE invites your written comments and suggestions.

SAE values your input. To provide feedback on this Technical Report, please visit <http://standards.sae.org/AS21923C>

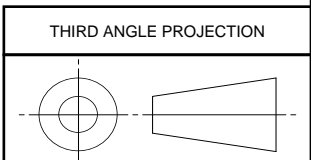

CUSTODIAN: G-3/G-3B

PROCUREMENT SPECIFICATION: AS18280 /11/



AEROSPACE STANDARD

(R) ADAPTER, FLARELESS TUBE, BULKHEAD AND UNIVERSAL TO FLARED TUBE

AS21923™
SHEET 1 OF 3

REV.
C

ISSUED 1998-08 REAFFIRMED 2007-01 REVISED 2017-01